

Vane Product Technical Catalog

Pumps & Components - V10/V20, V, VQ, SQP Series

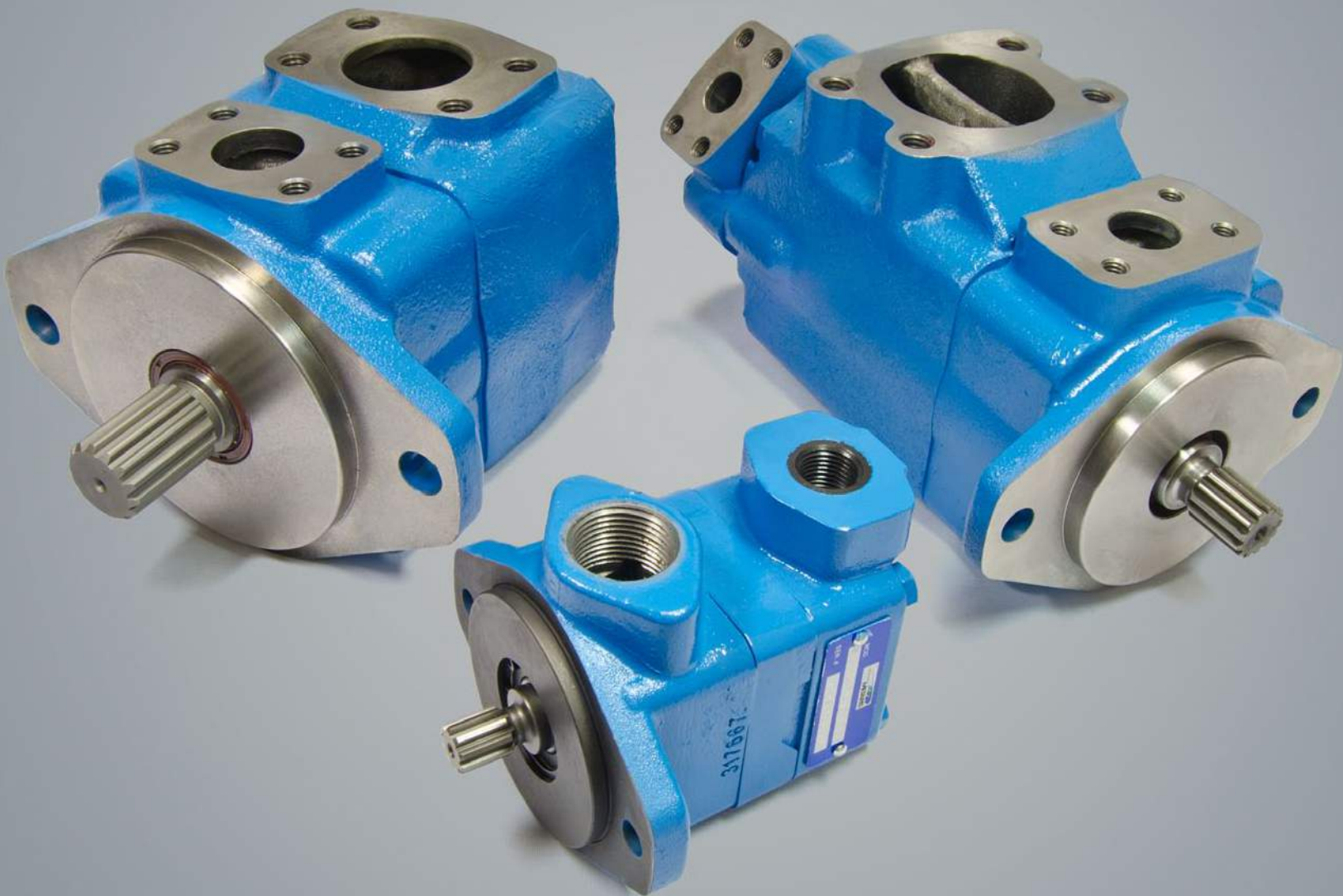

V10、20 系列叶片泵 / V10、20 Series Vane Pumps

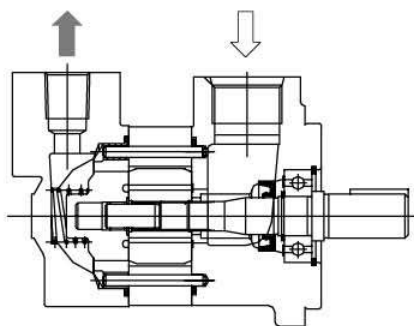

液压符号
Hydraulic Sign

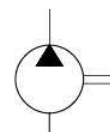

型号说明 Model Designation

(F3-)	V10	-P	7	S	-1	C	20	-L
前注 Note	系列号 Series	进口口连接 Inlet Connection	排量代号 Displacement	出油口连接 Outlet Connection	轴伸形式 Shaft Type	出油口位置 Outlet positions	设计号 Design number	旋转方向 Rotation Direction
Water-oil emulsions	V10	P-1"NPT Thread S-1.3125-12 Straight B-G1" Thread	1, 2, 3, 4, 5, 6, 7	P-1/2"NPT Thread S-0.750-16 Str. Thread B-G1/2" Thread	1- Key Straight Shaft 11- Spline Shaft 38-11teeth -3/4" outside spline shaft	(从泵的盖端看) (Viewed from cover end of pump) A-进油口对面 Opposite inlet port B-从进油口逆时针90° 90° CCW from inlet C-进油口同侧 Inline with inlet D-从进油口顺时针90° 90° CW from inlet	20	(从泵的轴端看) (Views from shaft end of pump) R-顺时针旋转 right hand for clockwise L-逆时针旋转 left hand for counter-clockwise
Water glycol fluid								
F3 phosphate ester fluid	V20	P-1-1/4"NPT Thread S-1.625-12 Straight B-G1-1/4" Thread	6, 7, 8, 9, 10, 11, 12, 13	P-3/4"NPT Thread S-1.0625-12 Straight R-1.1875-12 Straight B-G3/4" Thread	62- spline shaft (only for V20)	10		

技术参数/Technical Date

系列号 Series	排量代号 Displacement code	几何排量 Geometric displacement mL/r	使用抗磨液压油或磷酸酯液 With antiwear hydraulic oil or phosphate ester fluid		使用水乙二醇液 With water glycol fluid		使用油包水乳化液 With water-oil emulsions	
			最高压力MPa Max. pressure	最高转速r/min Max. speed	最高压力MPa Max. pressure	最高转速r/min Max. speed	最高压力MPa Max. pressure	最高转速r/min Max. speed
V10	1	3.3	17.2	4800	12.4	1800	10.3	1800
	2	6.6		4500				
	3	9.8		4000				
	4	13.1		3400				
	5	16.4		3200				
	6	19.5	15.2	3000	10.9			
	7	22.8	13.8	2800				
V20	6	19.5	17.2	3400	12.4	1800	10.9	1800
	7	22.8		3000				
	8	26.5		2800				
	9	29.7						
	10	30.0	15.2	2500	10.9	9.3		
	11	36.4						
	12	39		2400				
13	42.4							

特性曲线[50℃, 32cst油, 进油口压力0Mpa]

Performance Characteristics,[50℃, 32cst Oil, Input Pressure 0MPa]

◇ V10

Code 1 & 3 rings

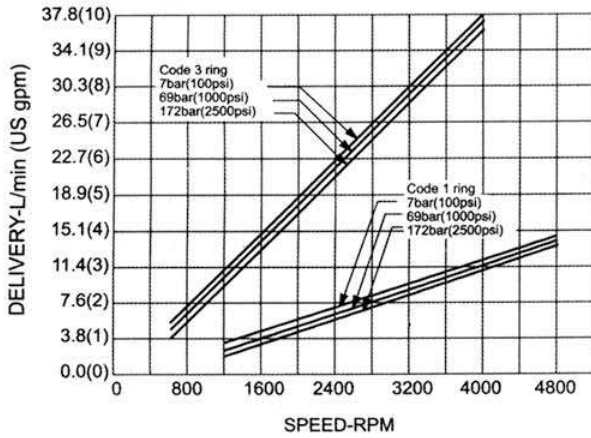

Code 2,4 & 6 rings

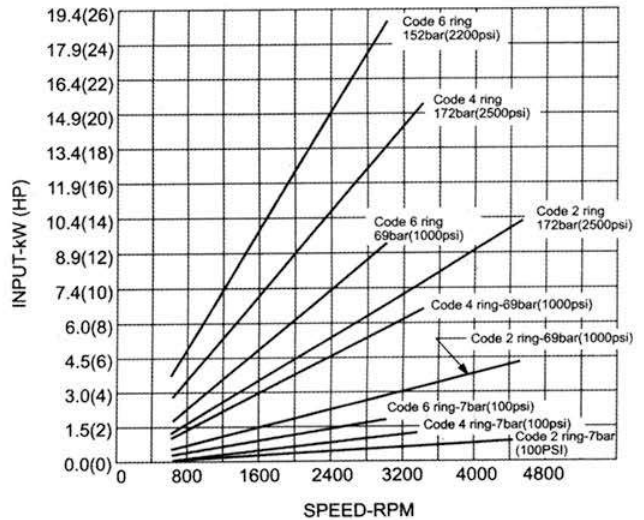
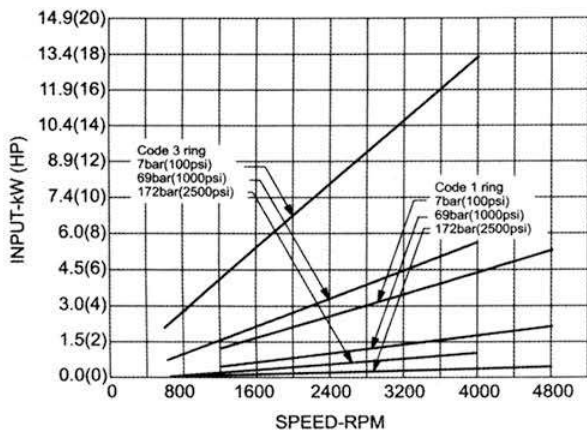
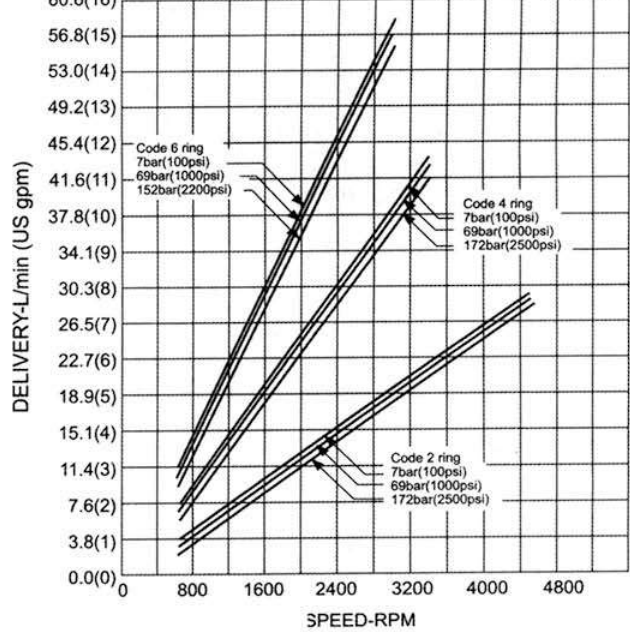

特性曲线[50°C, 32cst油, 进油口压力0MPa]

Performance Characteristics,[50°C, 32cst Oil, Input Pressure 0MPa]

◇ V10

Code 5 & 7 rings

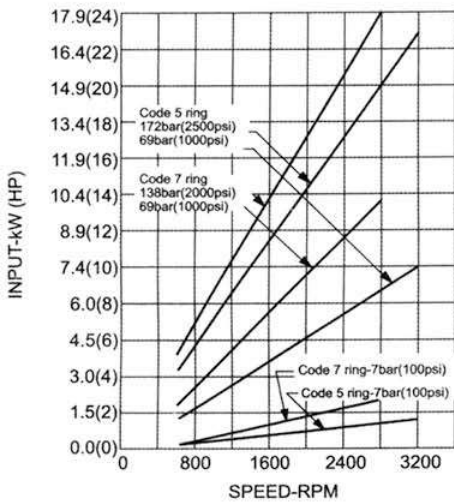
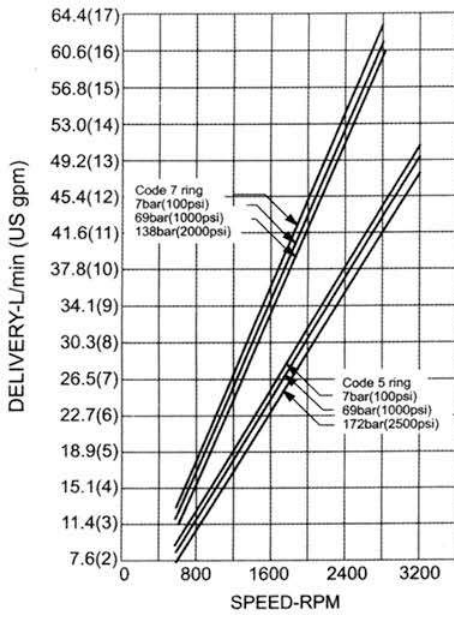

◇ V20

Code 6,8 & 12 rings

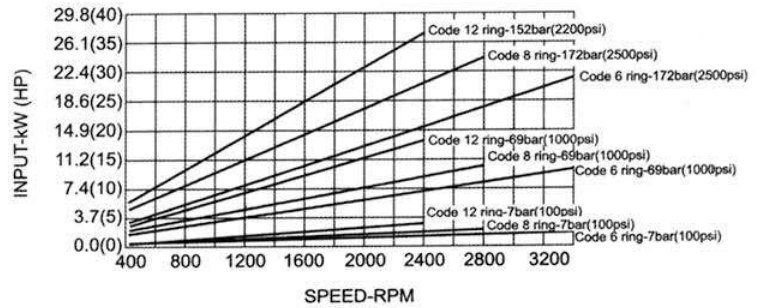
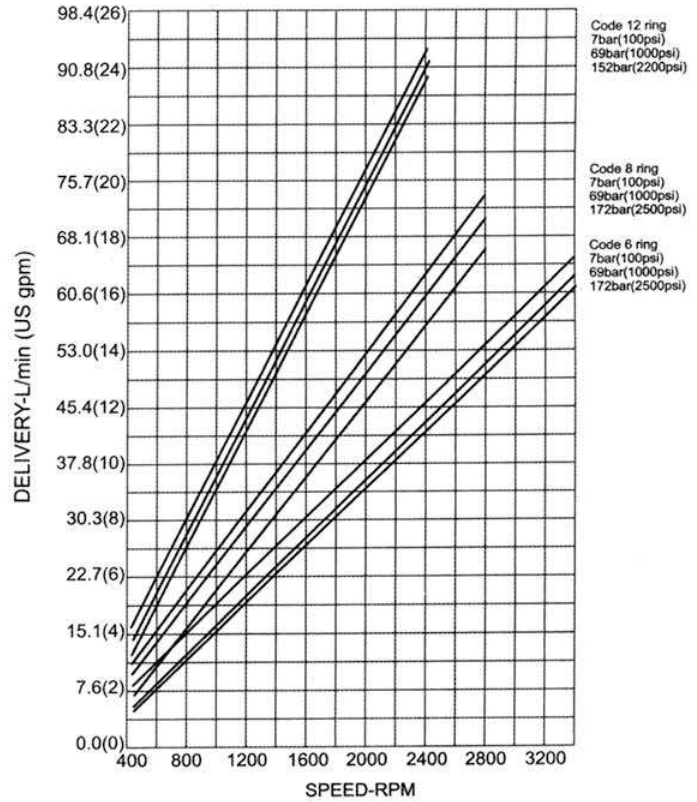

特性曲线[50°C, 32cst油, 进油口压力0Mpa]

Performance Characteristics,[50°C, 32cst Oil, Input Pressure 0MPa]

◇ V20

Code 7 & 13 rings

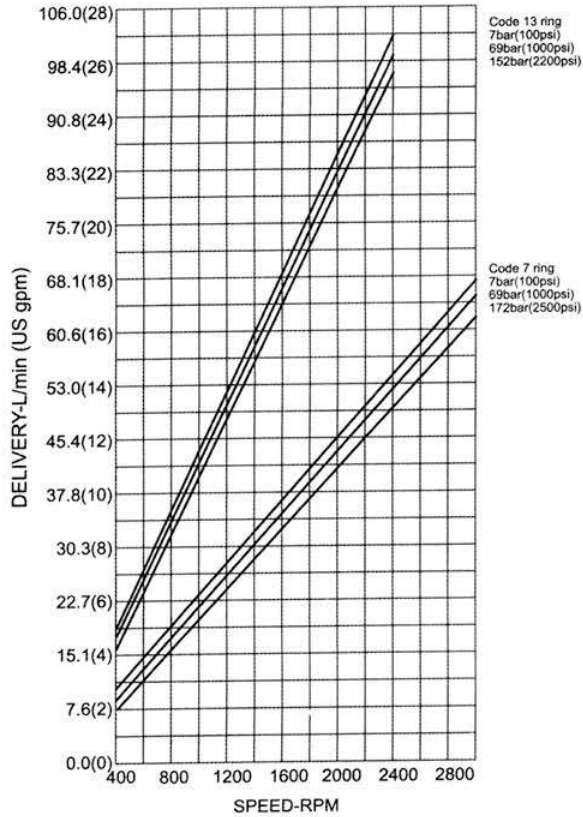

Code 9 & 11 rings

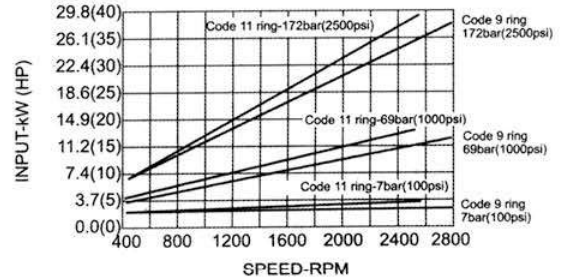
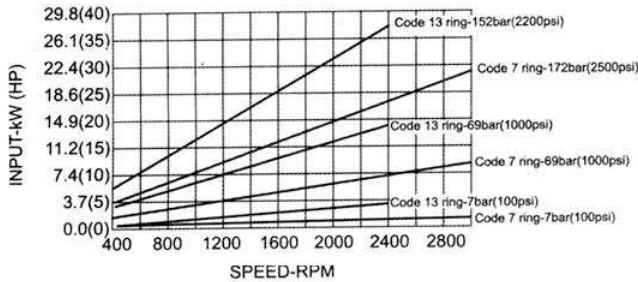
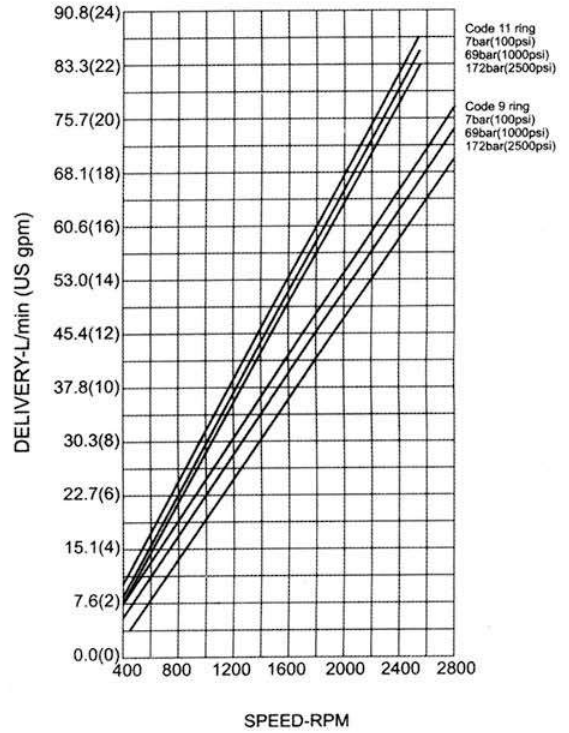

◇ V10

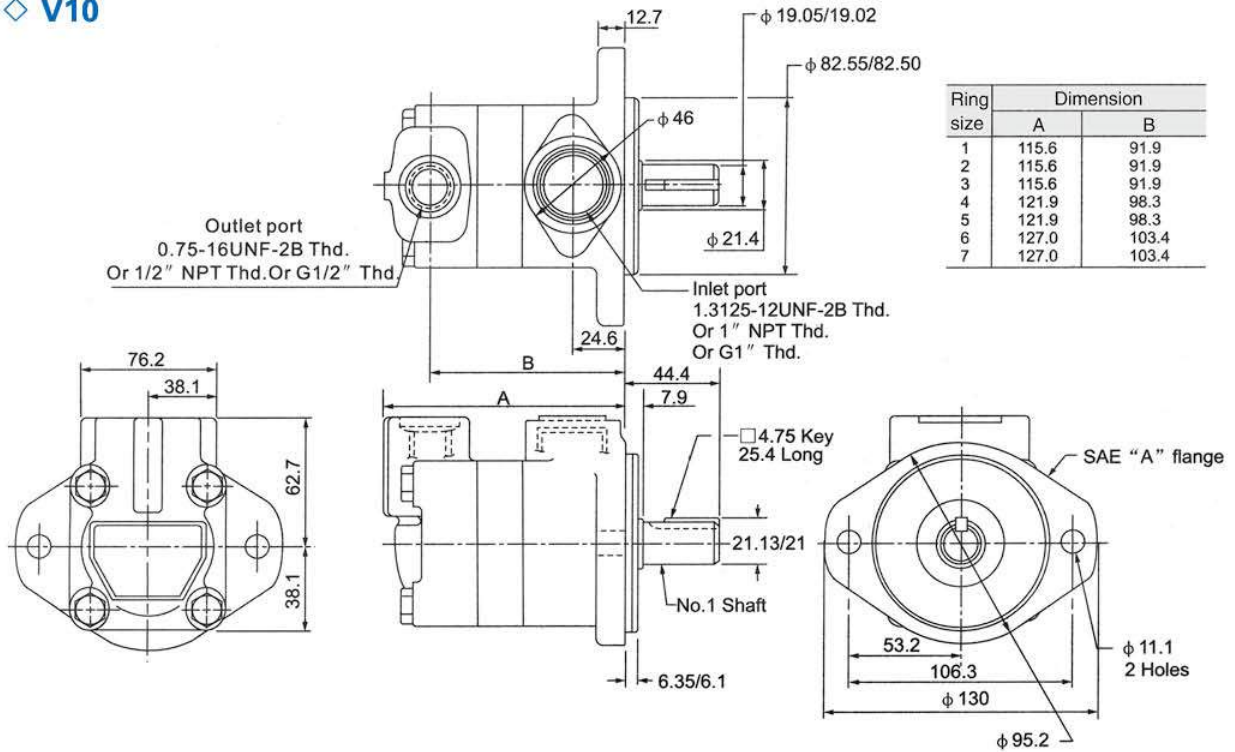

◇ V20

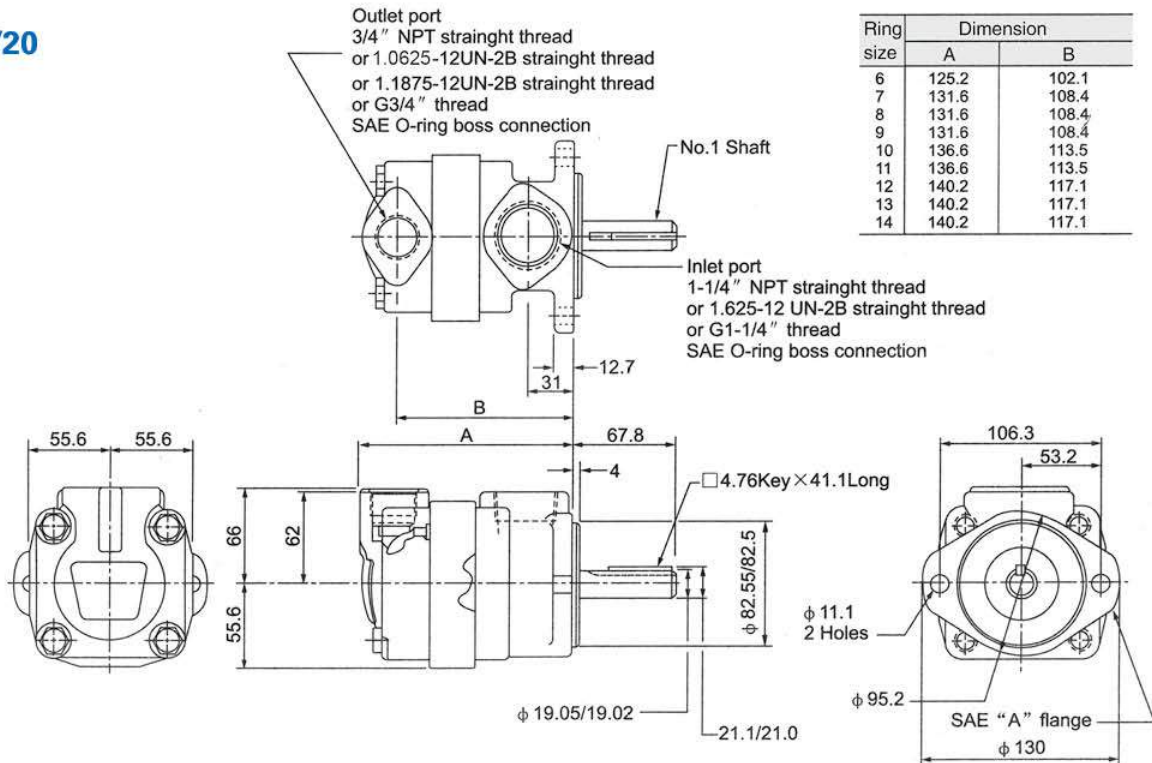

V10 Series Spline Shaft Type

11 Type Spline Shaft

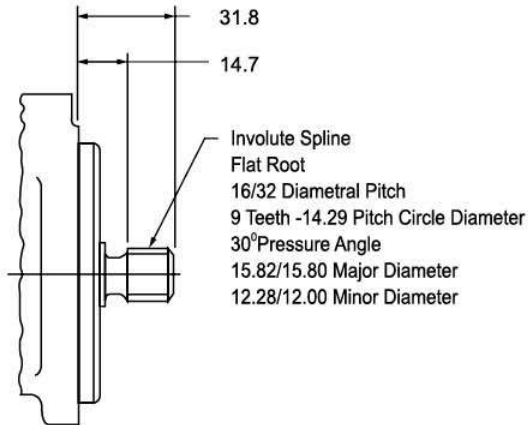

V20 Series Spline Shaft Type

11 Type Spline Shaft

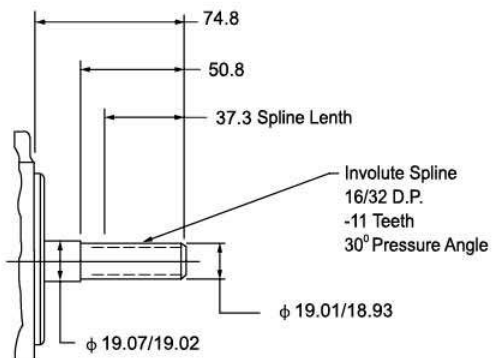

62 Type Spline Shaft

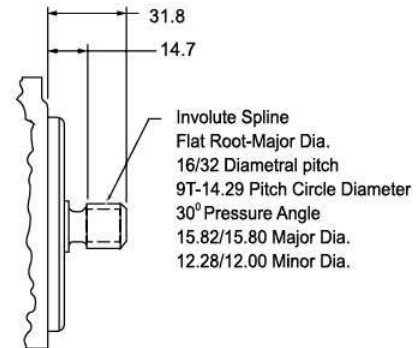

V、VQ、V10、V20、SQP、PV2R 安装、使用与维护

V、VQ、V10、V20、SQP、PV2R Installation, Application and Maintenance

◇ 工作介质

为提高油泵性能. 延长使用寿命, 推荐使用抗磨液压油. 粘度范围17-38cst(2.5-5°E), 推荐粘度24cst。

液压油的污染会引起叶片泵的故障和降低其寿命, 应对液压油液进行有效的污染控制, 系统过滤精度不低于25 μm。为防止吸入污物和杂质, 应在吸油口处安装过滤精度70-150 μm的滤油器, 其额定流量不低于泵流量的两倍。

油泵正常工作油温: 10-60℃。

◇ 泵的安装

油泵支架结构要牢固. 刚性好. 并能充分吸收振动。

油泵可安装成任何方向(最好水平放置)。泵和电机轴必须对正. 同轴度应控制在Φ0.1mm以内, 尽量采用柔性联轴节. 以避免因弯曲或侧向力引起的任何应力。

吸入阻力不应太高, 以防产生空蚀现象。油泵允许吸入真空度为110mm水银柱。安装应尽量接近油箱, 吸入高度不得大于500mm。

注意进油口处连接法兰、接头以及整个吸油管道必须严格密封, 防止漏气, 否则将会引起噪声、系统振动, 并使油箱内产生大量泡沫, 降低泵的寿命。

油泵的吸油管道通径不小于泵入口通径。

油箱应设有隔板, 用来分隔回油带来的气泡与脏物。回油管应伸到油面以下(不得直接和泵的入口连接), 防止回油飞溅引起气泡。

◇ 启动

油泵启动前, 应检查进、出口油, 切勿搞错方向, 泵旋转方向应与标牌指示方向一致(订货时未注明旋向者, 一律按顺时针旋向供货)。初次启动应向泵里注满油, 并用手转动联轴器。旋转力量应均匀、灵活。

启动时, 应尽量在无负荷工况下经点动运转正常后再正式启动。

由于泵装配后或长时间停运转再启动. 会产生吸空现象, 故应在排油口安装放气阀. 或松动出口法兰、接头, 以便放出空气。

◇ 维护

用户购回油泵后, 如不及时使用, 必须将内部注入防锈油, 并将外露加工表面涂防锈油脂, 然后盖好防尘盖. 妥善保存。

要定期检查油液一眈能. 达不到规定要求时要及时予以更换. 并清洗油箱。

滤油器应经常清洗. 以保证油液吸入通畅。

保持油箱正常油面高度。配管和油缸的容量很大时, 尽管最初已加入足够数量的油. 在启动之后. 油进入管道和油缸. 也会发生油面下降使滤油器露出油面, 因此必须再一次补油。在使用过程中, 还会发生泄漏. 应该在油箱中设置油面计, 以便经常观察和补油。

油泵工作一段时间后, (由于振动)安装螺钉或进出口口法兰螺钉有可能松动, 要注意检查, 并拧紧防松。

由于V、VQ、SQP、PV2R系列叶片泵内腔采用插装式结构, 因此正常维修时只需要更换泵芯. 更换时应检查密封圈是否平整, 防止切边, 拧紧壳体连接螺钉时. 应按对角线方向逐渐拧紧, 用力均匀。

◇ Operating oil

Anti-wear hydraulic oil is recommended for better performance and longer life. Viscosity range: 17-38cst(2.5-5°E).

Proper fluid condition is essential for long and satisfactory life of hydraulic components and systems. filtration: the filtration rating should not be lower than 25 μm. filter of 70-150 μm on the inlet port is recommended and its delivery should not be lower than 200% that of pump.

Operating temperature: 10-60℃.

◇ Installation

Foot and frame for pump must be reliable, solid and good in vibration absorbence.

Horizontal mounting is recommended to maintain necessary case fluid level, concentricity of shafts between pump and motor is important to pump life and should be within Φ0.1 mm. It is better to use flexible coupling to avoid harmful effects.

The oil pump allows the inhalation vacuum as 110 mm column of mercury. Installation should near fuel tank, inhaling the height can not be big in 500 mms.

To reduce noise and vibration of system caused by trapped air, attachment flange at inlet port, all fittings and pipelines must be strictly sealed.

The diameter of absorb pipeline should not smaller than that of inlet.

There should be a plank in the tank to separate bubble and dirty thing from used oil. Return pipeline under oil is recommended(not connect with inlet) for avoid bubble.

◇ Start

Before starting pump, please check up if the inlet and outlet have been correctly connected and the rotation of the pump is inline with the nameplate. (CW without notice).

After confirming it is able to work well without burthen, please start.

When initially starting the pump after long-time unused, removing all trapped air from the system can be accomplished by loosening flange or connections.

◇ Maintenance

Please inject defend rust oil in the pump, plait the surface with defend rust grease and then cover ports, if you do not want to use it right now.

Please check up oil periodically, while if the oil can not meet the demand, replace it and clean up tank.

Purging of filter regular is recommended.

Keep the normal level of oil in the tank. When capability of tubing and tank are large, even if injected enough oil. Because when starting, the level of oil would fall, then please add some oil. Please observe the level of oil and add some oil when needed.

After a period of working, it is likely that the install bolt and flange of inlet and outlet would loose because of vibrating, please tight them.

The cartridge design of V、VQ、SQP、PV2R series vane pumps offers fast and efficient field service ability, when replacing the cartridge, seals inside the pump should be checked to avoid them crimping; when tightening the fastening screws, they should be treated with even force in diagonal direction.